

Top Shear Type Pneumatic Shear Knifeholder MT-A450L

MT-A450L is new designed for flexible application and improving operational efficiency. It has cant angle adjustable and replaceable bottom make easier to use at different web direction. The new function, self flow control can prevent damage blade when operation, and another like micrometer, with same structure the micro depth adjustment enhance control overlap distance accuracy up to 0.05mm.

MT-A450L offer a wide range of slitting material including plastic, paper, copper foil..etc., thickness under 0.4mm and slit width within 53mm application.

» Feature

- Min slitting width 53mm
- Self flow control
- Micro depth adjustment
- Individual control valve
- Cant angle adjustment
- Replaceable bottom knife holder
- Position displacement adjust

» Specification

- Min. slitting width : 53mm
- Max. slitting speed : 400M/min (1)
- Down stroke range : 0~20mm
- Side contact range : 0~3mm
- Top blade dia. : $\phi 105$ mm
- Guide-bar : GB02/GB04/GB05

Patent Number

Taiwan M487158/M487795/M491566

China ZL2014 2 0364499.X / ZL2014 2 0363283.1

ZL2014 2 0363247.5 / ZL2014 3 0217718.7

(1) Max slitting speed depends on different material and the condition will be changed.

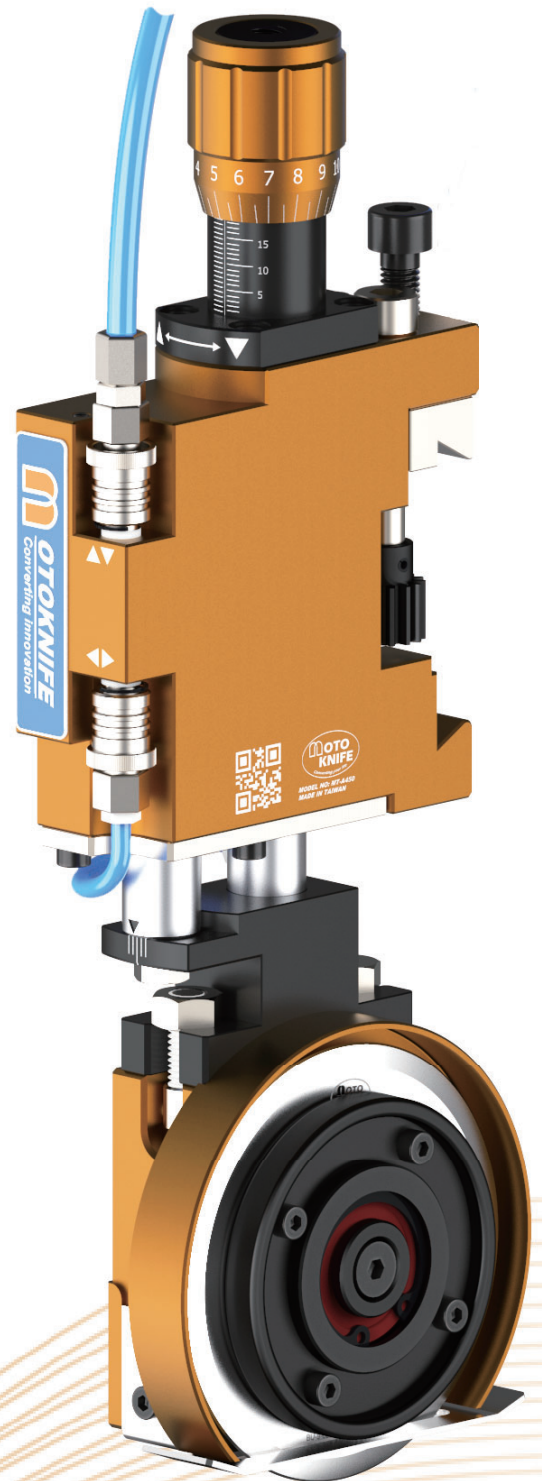

MT-A450L

MOTOKNIFE

MT-A450 Dimension drawing

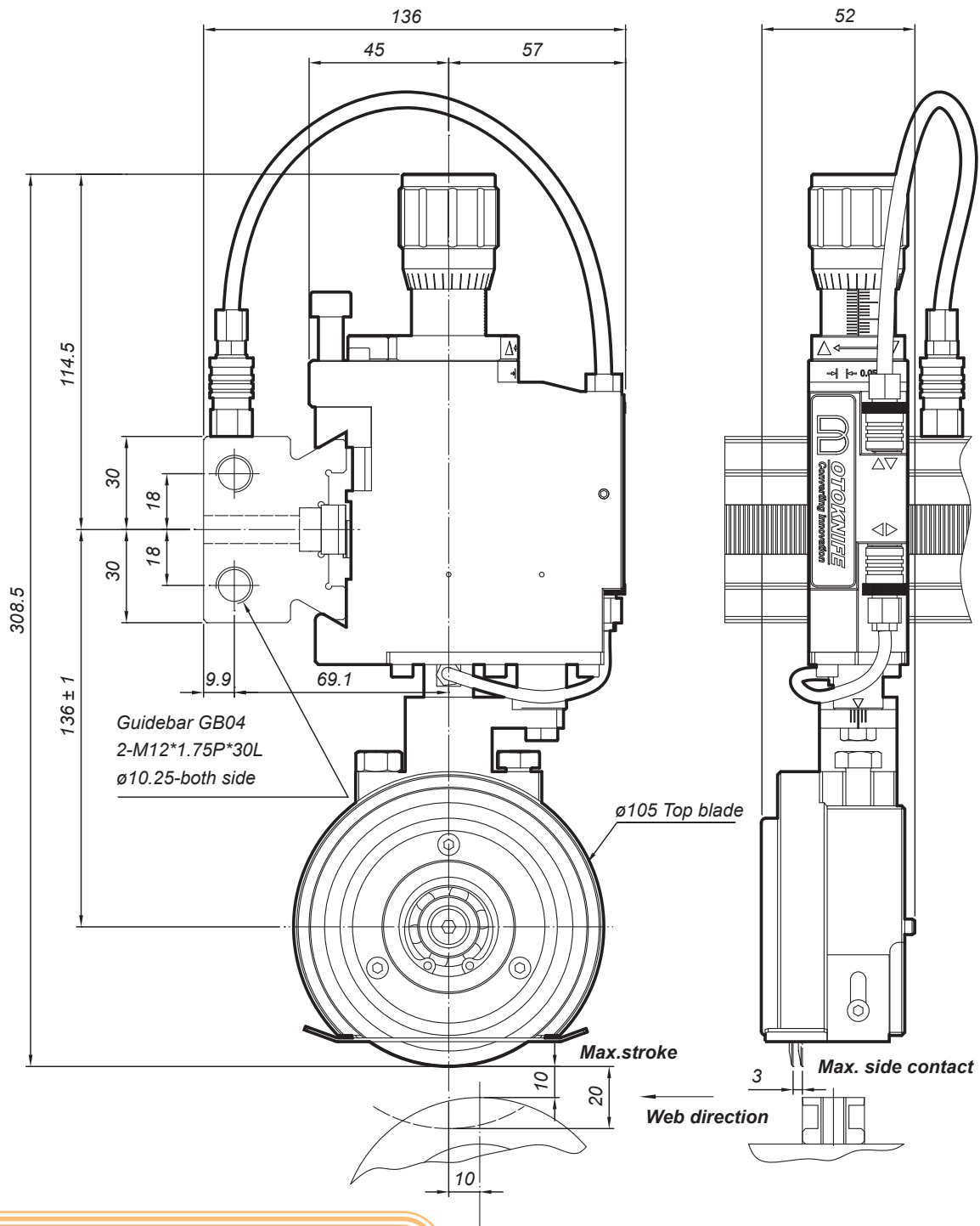

Blade dimension drawing

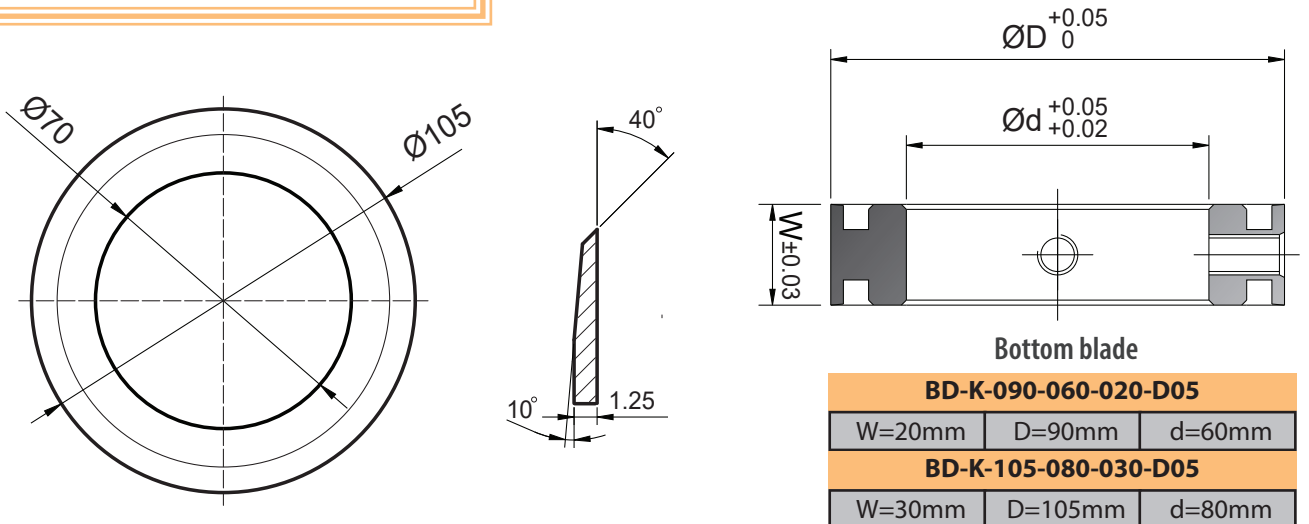

Different web path arrange

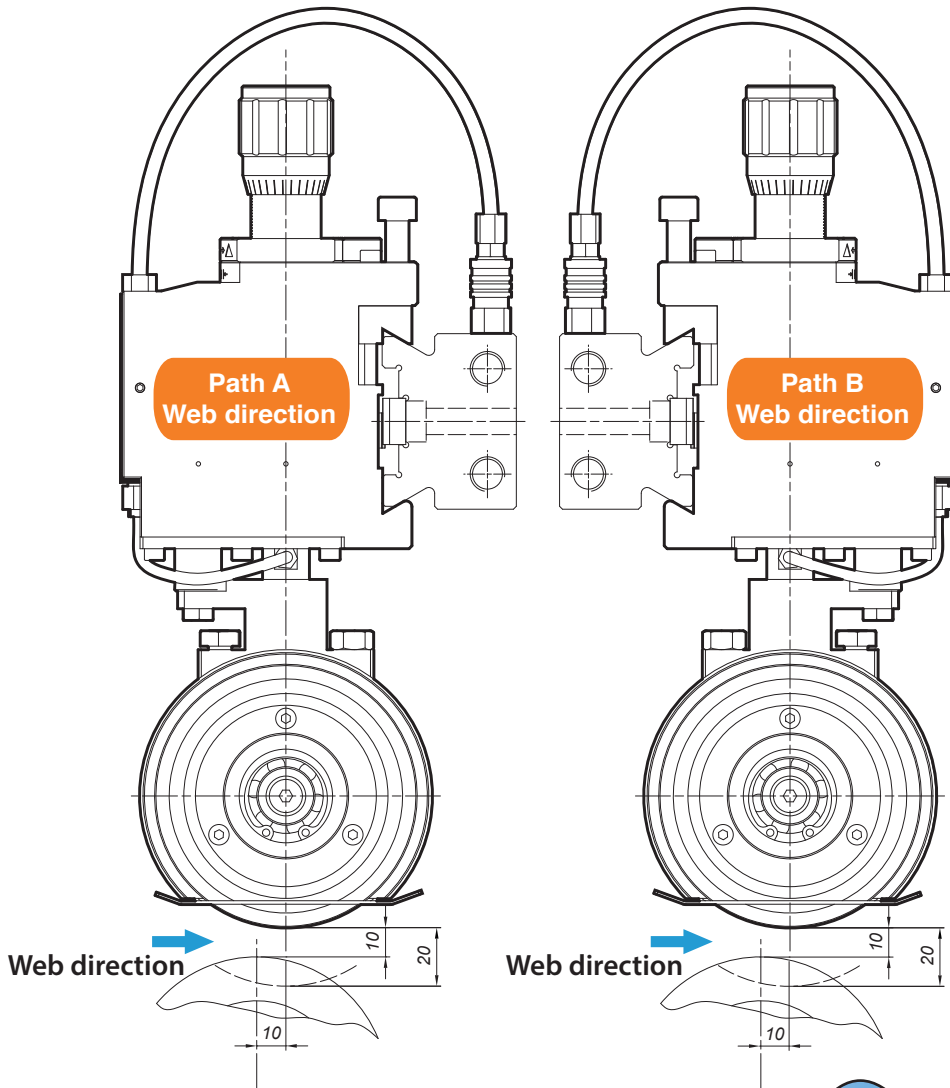

Different Web Path

Easily changeable cant angle can be for different web path direction application, in order to obtain better slitting effect correct cant angle setup is very important!!

Knifeholder direction arrange

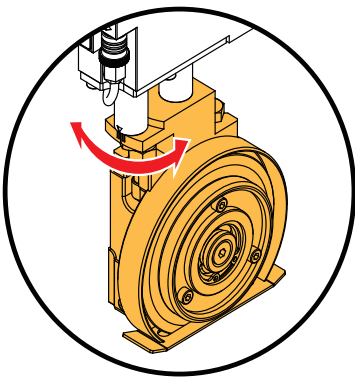

Cant angle adjust

For various material slit condition, you only need to unlock one screw and easily adjust the cant angle for different purposes to get a better efficiency result.

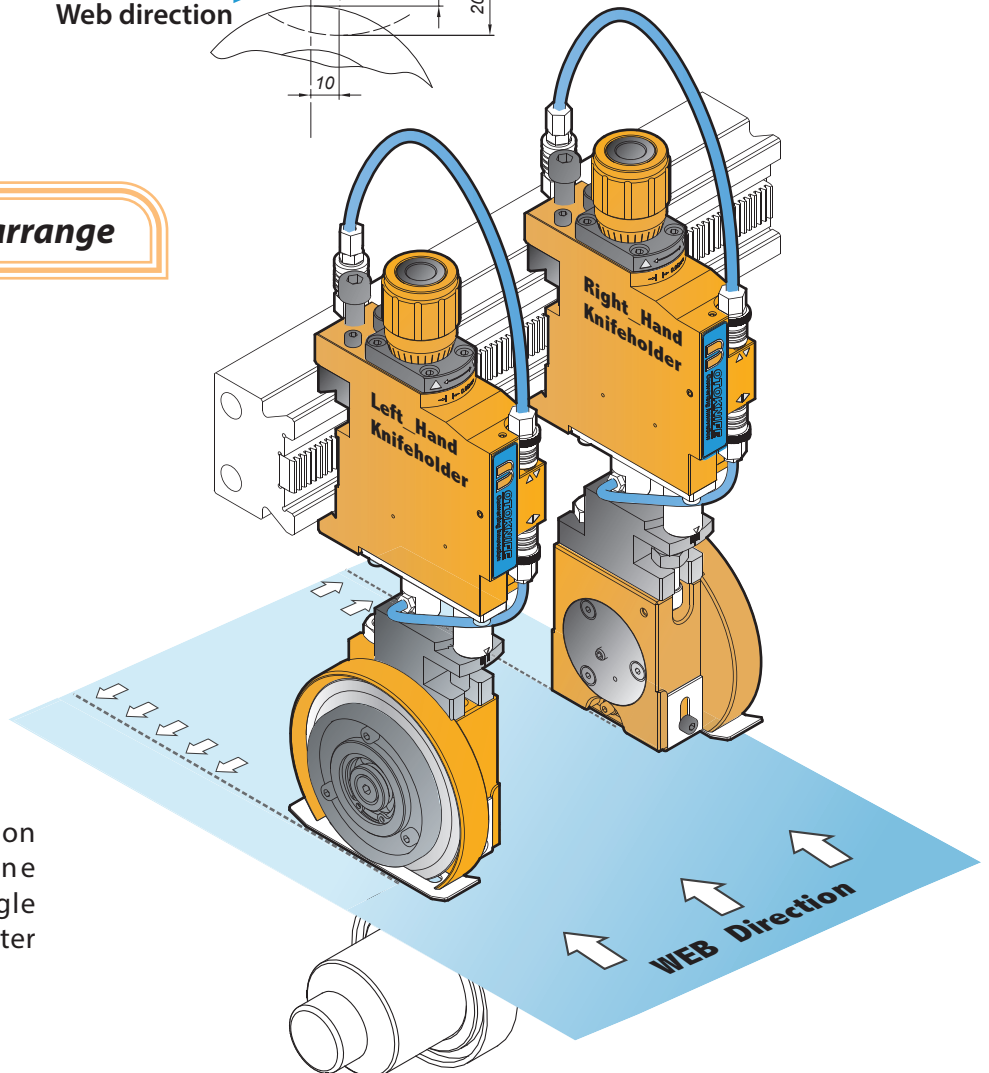

Saving setting time

Using gear and rack on guide-bar to adjust knifeholder position ,make setting correct position easy and fast.

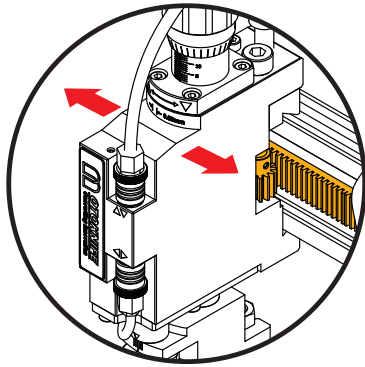

Internal air flow control

Patent design with internal air flow control, you can directly connect air source without air throttle valve and never worry too much air flow to damage blade!!

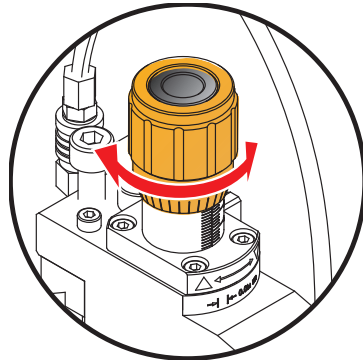
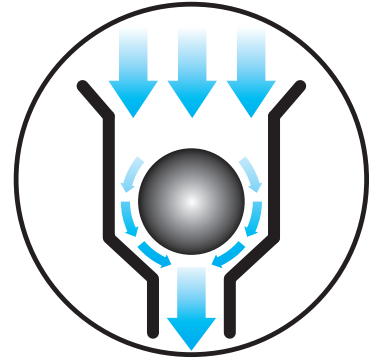

Precision depth adjust

Using depth adjustment can easily control down stroke and the accuracy up to 0.05mm, it is helpful for overlap compensation when blade wear.

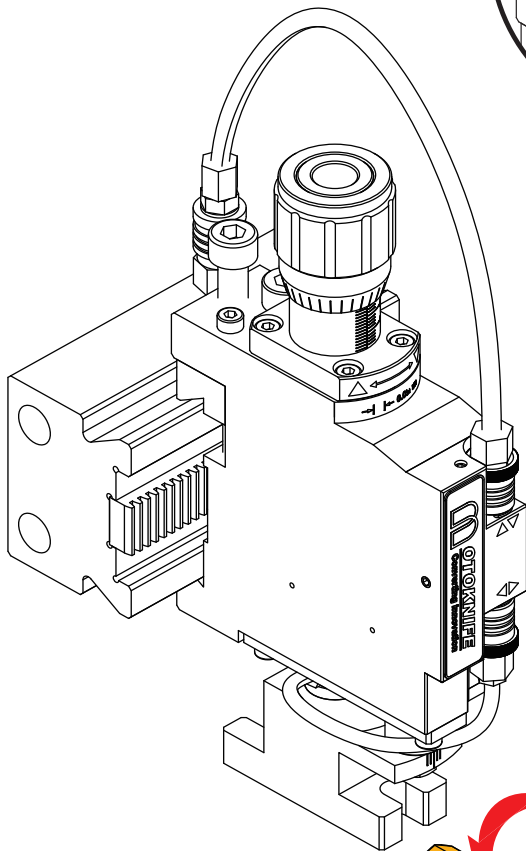

Individual valve control

More convenient for down stroke and side contact individual valve control, it can be operation under automatic action or separate when arrange position.

Down stroke

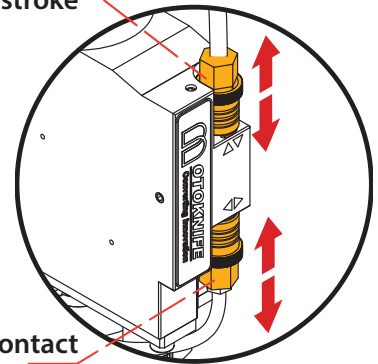

Side contact

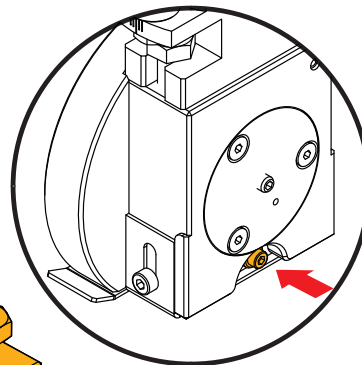

Easy blade replace

Only push down the blade replace button and rotate shaft until lock position ,it can be lock shaft rotate and easily relpace blade.

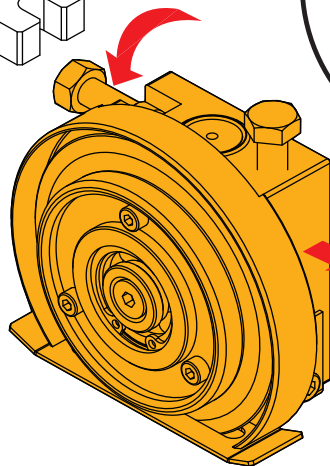

Changeable knifeholder

Depending on the application ,user can arrange left or right side bottom knifeholder to getting better slitting result by change bottom knifeholder.

MT-A450L

MOTOKNIFE

